

SERVAIS SILENCERS, 409 HARLESTONE ROAD, NORTHAMPTON NN5 6PB

Telephone: +44 (0) 1604 754888 Fax: +44 (0) 1604 759548

Email: keith@servais.co.uk Web: www.servais.co.uk

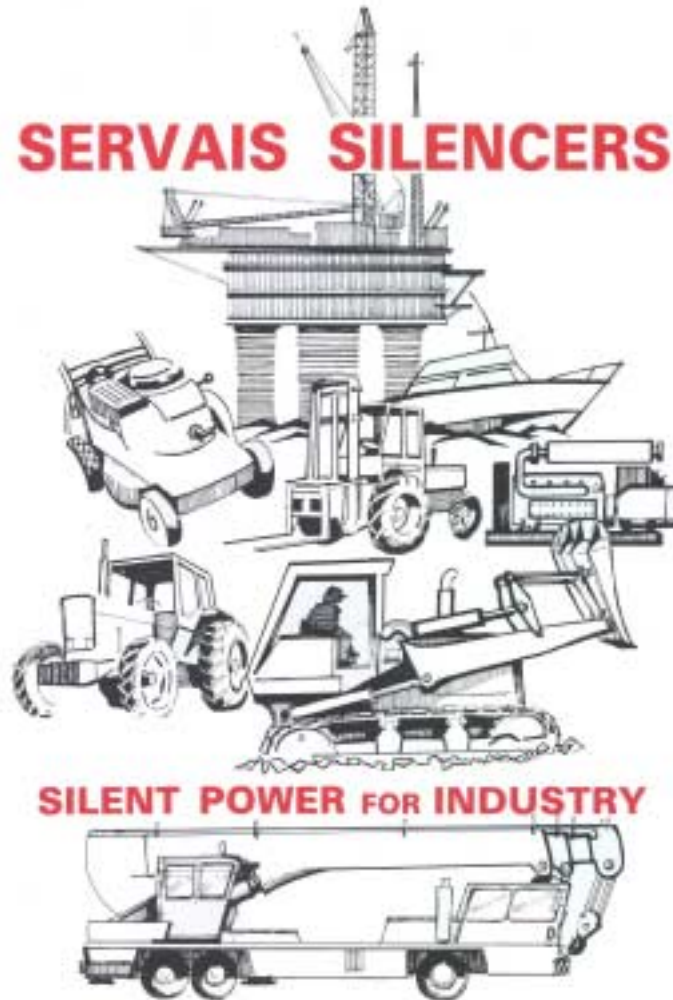

Servais Silencers have been established as independent manufacturers of industrial silencing systems for over 60 years. Current production is mainly for original equipment manufacturers of fork lift trucks, and other special bodied vehicles such as cranes, earth moving equipment, road rollers etc., and for diesel generator manufacturers and stationary equipment using diesel engines. We also manufacture silencers for other types of gas and air systems, including air filters and air filter silencers for fans, blowers and compressors, steam discharges and process silencing.

A wide range of allied equipment is also offered, including spark arrestors, flame traps, rain caps, pipe work, flexible connectors, flanges, gaskets and catalytic converters.

Servais are now one of the most well-established and best known manufacturers of industrial silencers in the UK with a worldwide reputation for heavy duty, high quality silencers. The company is currently exporting to many countries.

We always aim to adapt to customers requirements with production in small batch quantities or even one off's if necessary. A comprehensive library of information on diesel engines is maintained and the company can draw on 53 years experience in recommending a suitable exhaust for any problem.

## SERVAIS SILENCER TYPE SN112

### MEDIUM DUTY ABSORPTIVE INDUSTRIAL SILENCERS

#### General Specification

These silencers can be used on either diesel exhausts or air systems. They are constructed on the sound absorption principle. The gases pass through a centre duct surrounded by sound absorbent material and the minimum resistance is offered to the gas flow.

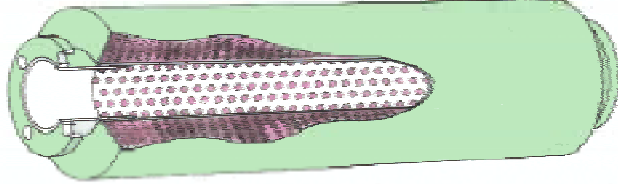

#### Construction

A cylindrical steel body with all welded seams. End plates for sizes 25mm - 100mm nominal bore (1" - 4") from heavy steel pressings and for larger sizes manufactured from flat plate.

#### End Connectors

Unless otherwise specified, screwed BSP connectors will be supplied on 25mm - 76mm (1" -3") silencers and flanges to BS10 (Table D) on all larger sizes. Flanges to other standards can be supplied on special quotation.

#### Air Silencers

When intended for use as Air Silencers, specify SN112(PD) when ordering. The centre duct is then wrapped in a protective material which prevents the acoustic filling being drawn into the air stream. Alternatively, silencers can be supplied with acoustic foam filling, for use, for example in the food industry, but there are temperature restrictions. Details on application. Specify SN112(FO) when ordering.

**SERVAIS SILENCER TYPE SN112**

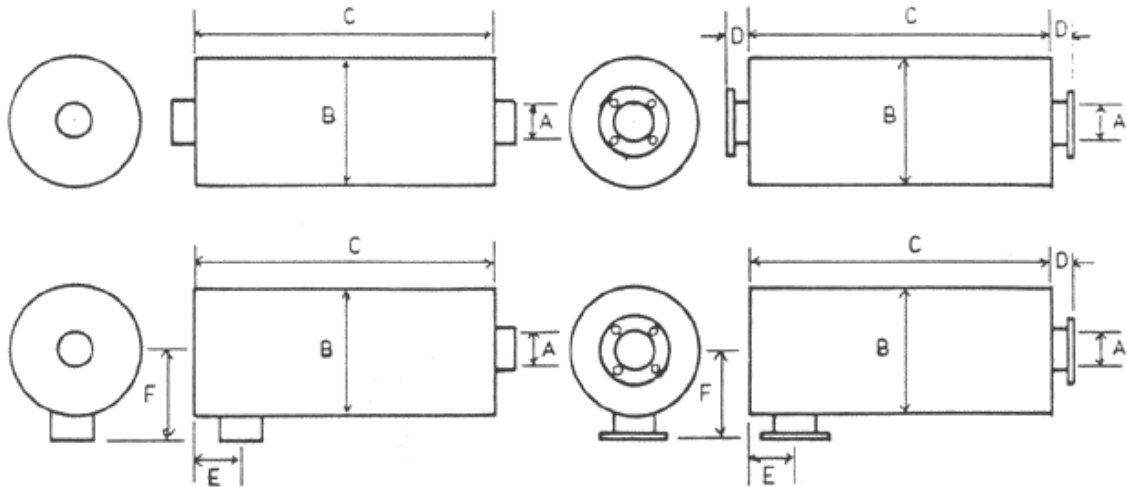

Nominal Bore (A)	Diameter (B)	Length (C)	(D)	(E)	(F)	Approx. weight (kilos)	Capacity m <sup>3</sup> /min for SN112(PD)
25 (1")	89 (3½")	381 (15")		38		1.8	0.5 - 0.8
32 (1¼")	89 (3½")	381 (15")		38		2	0.8 - 1.3
38 (1½")	121 (4¾")	610 (24")		50		4	1.3 - 1.8
50 (2")	133 (5¼")	762 (30")		50		6	1.8 - 3.3
64 (2½")	152 (6")	762 (30")		63		9	3.3 - 5.0
76 (3")	178 (7")	762 (30")		63		11	5.0 - 7.5
89 (3½")	178 (7")	914 (36")	50	75	140	16	7.5 - 10
100 (4")	229 (9")	914 (36")	50	80	165	20	10 - 13
125 (5")	305 (12")	914 (36")	50	83	203	32	13 - 20
150 (6")	356 (14")	1219 (48")	76	102	254	59	20 - 30
200 (8")	406 (16")	1524 (60")	76	127	279	65	30 - 55
250 (10")	457 (18")	1829 (72")	76	203	305	136	55 - 80
300 (12")	610 (24")	2438 (96")	102	250	406	227	80 - 120
350 (14")	610 (24")	2438 (96")	102	250	406	234	120 - 160
400 (16")	762 (30")	2743 (108")	102	250	483	352	160 - 215
450 (18")	762 (30")	2743 (108")	102	280	483	365	215 - 270
500 (20")	762 (30")	3000 (118")	102	305	483	500	270 - 340
550 (22")	762 (30")	3200 (126")	102	330	483	550	340 - 400
600 (24")	810 (32")	3658 (144")	102	355	507	814	400 - 480

Note: Dimensions in millimetres (figures in brackets are inch equivalents).

SERVAIS SILENCER TYPE SN112

Typical Noise Attenuation Graph

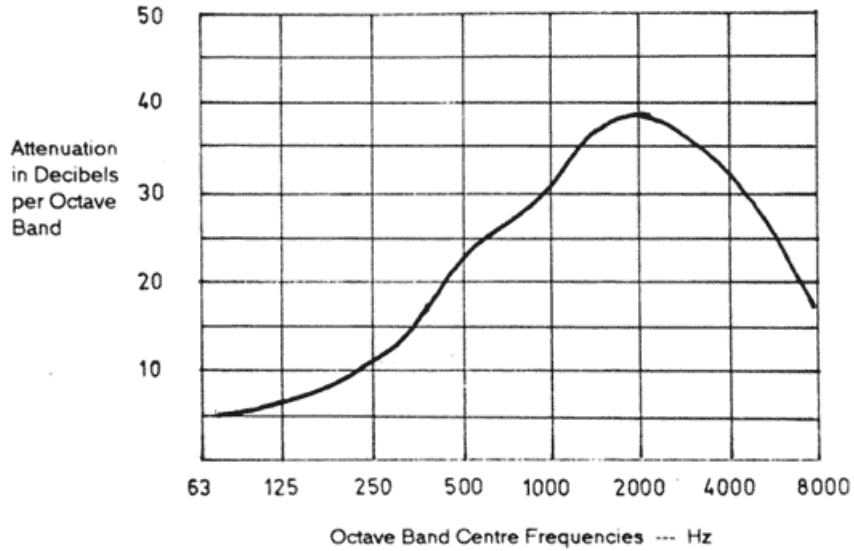

The above graph is based on simplified theoretical considerations and extrapolated from various noise tests. The actual noise reduction obtained on any particular installation will depend upon the power and type of the noise source, the local environment and the selection of the correct size of silencer for that engine.

SERVAIS SILENCER TYPE SN112

Velocity / Resistance Graph

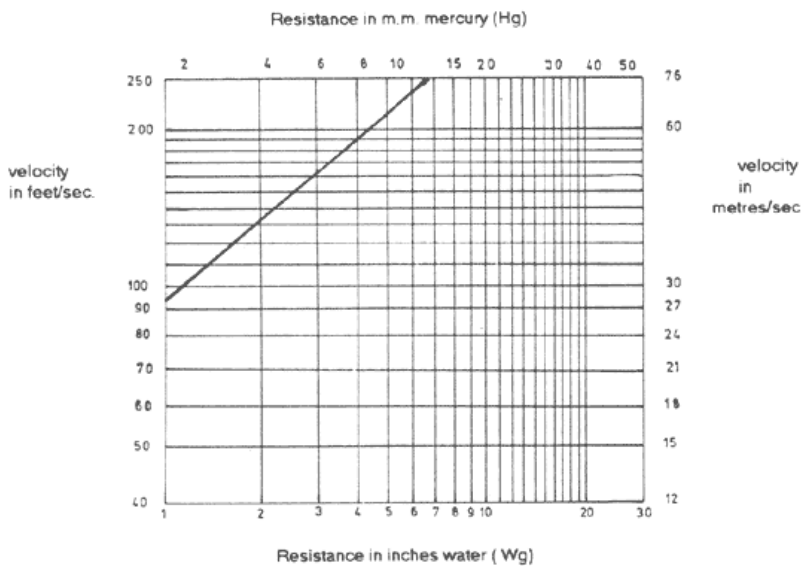

This graph is based on simplified theoretical considerations and is issued as a guide. The actual resistance experienced will depend on a number of factors affecting the individual installation. If you have any questions relating to this or any of our products, please do not hesitate to contact us.

SERVAIS SILENCER TYPE SN114

"RESIDENTIAL" TYPE SILENCERS

General Specification

These silencers incorporate an expansion and multi pass section to attenuate the lower frequency sounds and a sound absorption section to attenuate the higher frequency sounds.

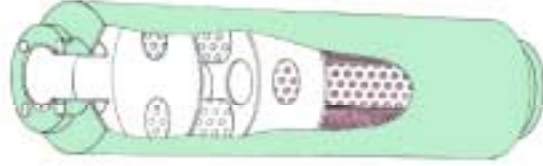

Construction

A cylindrical steel body with all welded seams. End plates for sizes 25mm - 76mm nominal bore (1" - 3") from heavy steel pressings and for larger sizes manufactured from flat plate.

End Connectors

Unless otherwise specified, screwed BSP connectors will be supplied on 25mm - 76mm (1" -3") silencers and flanges to BS10 (Table D) on all larger sizes. Flanges to ASA, 4504, DIN or other standards can be supplied on special quotation.

Side Entry Silencers

If these are required, please specify SN114 (SE) when ordering.

SERVAIS SILENCER TYPE SN114

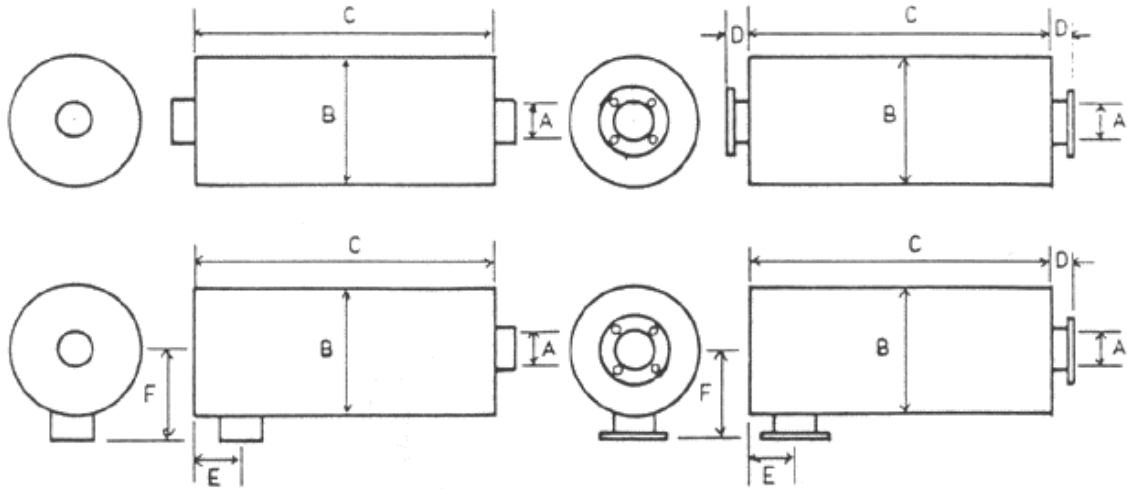

Nominal Bore (A)	Diameter (B)	Length (C)	(D)	(E)	(F)	Approx. weight Kilos
25 (1")	121 (4¾")	470 (18½")		38		3
32 (1¼")	121 (4¾")	470 (18½")		38		3
38 (1½")	121 (4¾")	470 (18½")		50	98	3
50 (2")	140 (5½")	635 (25")		50	121	5
64 (2½")	178 (7")	749 (29½")		50	140	7
76 (3")	203 (8")	876 (34½")		63	152	14
89 (3½")	254 (10")	914 (36")	50	75	190	28
100 (4")	279 (11")	1054 (41½")	50	75	216	34
125 (5")	356 (14")	1054 (41½")	50	83	254	54
150 (6")	406 (16")	1219 (48")	76	95	279	73
200 (8")	508 (20")	1676 (66")	76	127	356	152
250 (10")	610 (24")	2134 (84")	76	152	406	245
300 (12")	762 (30")	2743 (108")	102	203	533	363

Note: (i) Dimensions in millimetres. (Figures in brackets are inch equivalents)

(ii) B.S.P. Drain plug at inlet end is available as an optional extra.

SERVAIS SILENCER TYPE SN114

Typical Noise Attenuation Graph

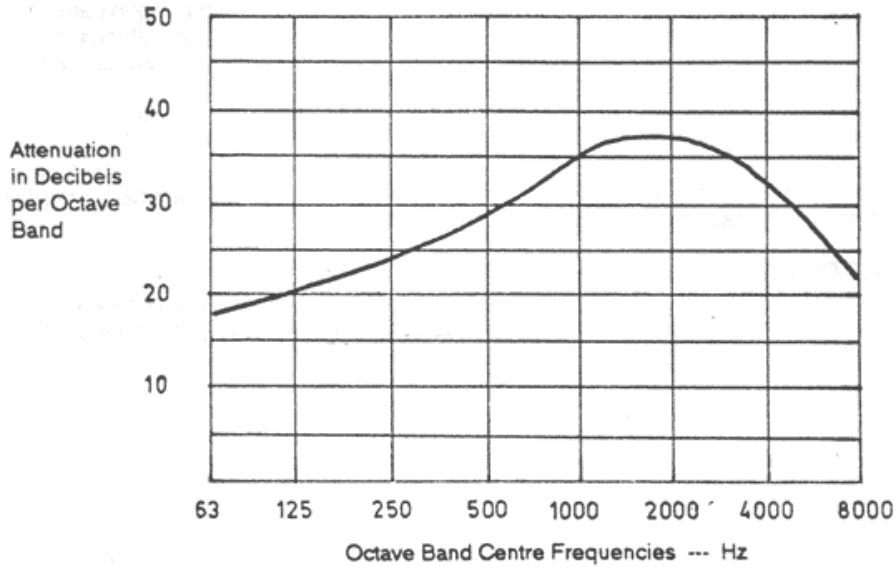

The above graph is based on simplified theoretical considerations and extrapolated from various noise tests. The actual noise reduction obtained on any particular installation will depend upon the power and type of the noise source, the local environment and the selection of the correct size of silencer for that engine.

Velocity / Resistance Graph

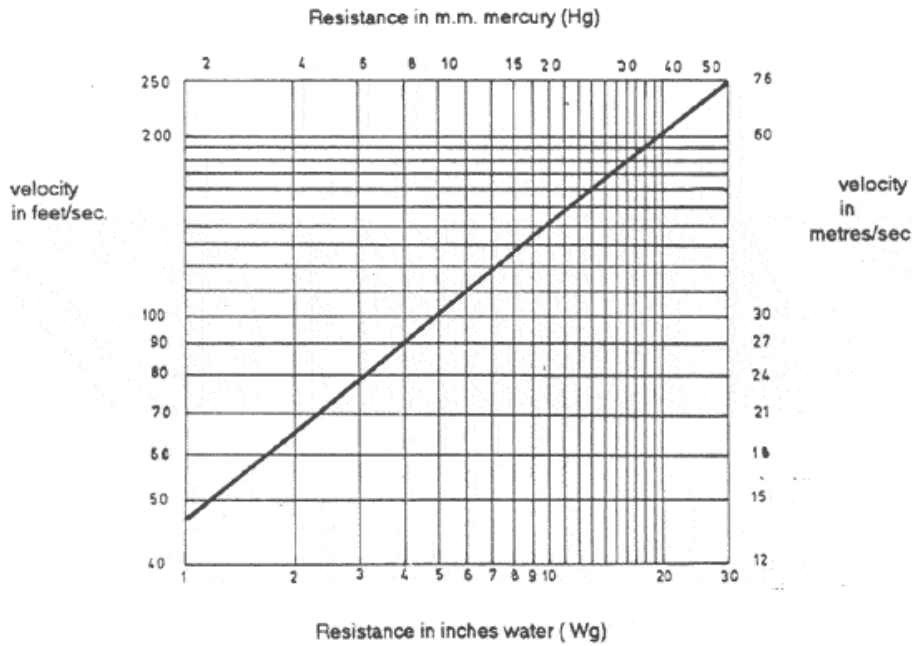

This graph is based on simplified theoretical considerations and is issued as a guide. The actual resistance experienced will depend on a number of factors affecting the individual installation. If you have any questions relating to this or any of our products, please do not hesitate to contact us.

SERVAIS SILENCER TYPE SN115

"MEDIUM DUTY" EXHAUST SILENCERS

General Specification

These silencers incorporate a multiple pass section to smooth the gas flow and a sound absorption section to attenuate the higher frequency sounds. They are suitable where moderate sound attenuation is required but space is limited. If higher attenuation is required and space is not restricted, we advise fitting an SN 114 or SN 116 type.

Construction

A cylindrical steel body with all welded seams. End plates for sizes 25mm - 76mm bore (1" - 3") are heavy steel pressings and for larger sizes are manufactured from flat plate.

End Connectors

Unless otherwise specified, screwed BSP connectors will be supplied on 25mm - 76mm (1" - 3") silencers and flanges to BS10 (Table D) on all larger sizes. Flanges to other standards can be supplied on special quotation.

Side Entry Silencers

If these are required, please specify SN 115(SE) when ordering.

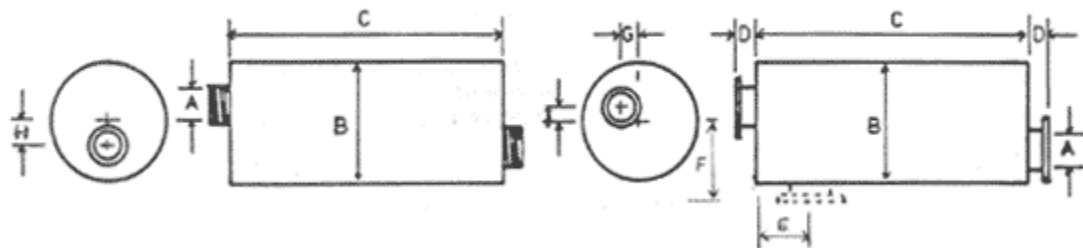

Nominal Bore (A)	Diameter (B)	Length (C)	(D)	(E)	(F)	(G)	(H)	(I)	Approx. weight (kilos)
25 (1")	95 (3¾")	254 (10")		38		14	16	8	1.5
32 (1¼")	95 (3¾")	305 (12")		38		17	21	11	2
38 (1½")	121 (4¾")	381 (15")		50		21	24	13	3
50 (2")	133 (5¼")	508 (20")		50		27	30	14	4.5
64 (2½")	178 (7")	610 (24")		50		33	38	19	7
76 (3")	203 (8")	737 (29")		63		41	48	22	12
89 (3½")	254 (10")	737 (29")	76	75	203	44	51	25	21
100 (4")	279 (11")	889 (35")	76	75	216	52	59	29	27
125 (5")	356 (14")	889 (35")	76	83	254	65	75	37	32
150 (6")	406 (16")	1000 (39")	76	95	279	78	89	44	57

Note (i) all dimensions in millimetres. (Figures in brackets are inch equivalents)

SERVAIS SILENCER TYPE SN115

Typical Noise Attenuation Graph

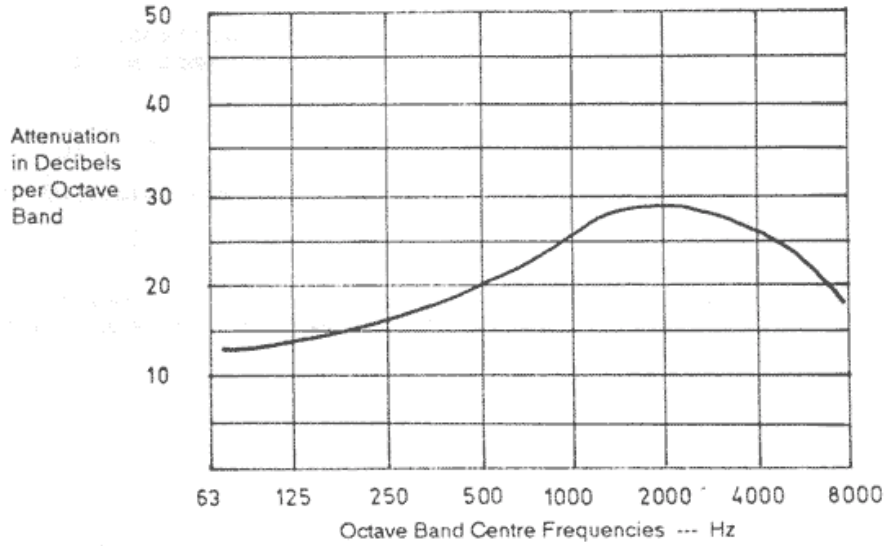

The above graph is based on simplified theoretical considerations and extrapolated from various noise tests. The actual noise reduction obtained on any particular installation will depend upon the power and type of the noise source, the local environment and the selection of the correct size of silencer for that engine.

Velocity / Resistance Graph

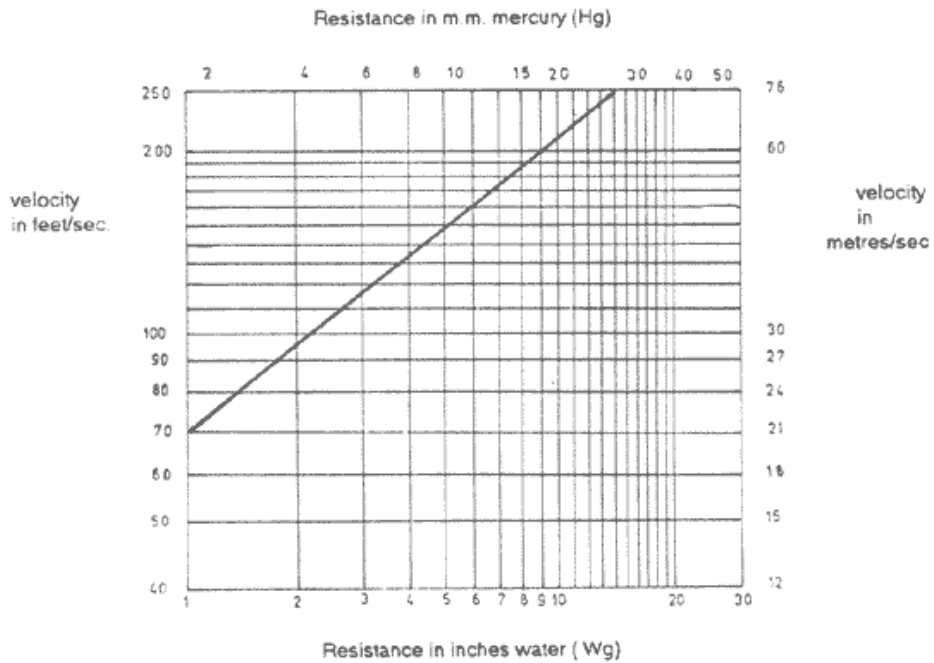

This graph is based on simplified theoretical considerations and is issued as a guide. The actual resistance experienced will depend on a number of factors affecting the individual installation. If you have any questions relating to this or any of our products, please do not hesitate to contact us.

SERVAIS SILENCER TYPE SN116

"HIGH ATTENUATION" EXHAUST SILENCERS

General Specification

These silencers incorporate a multiple pass section to smooth the gas flow and a sound absorption section to attenuate the higher frequency sounds. They are suitable where greater sound attenuation is required and space is available.

Construction

A cylindrical steel body with all welded seams. End plates for sizes 25mm - 76mm bore (1" - 3") are heavy steel pressings and for larger sizes are manufactured from flat plate.

End Connectors

Unless otherwise specified, screwed BSP connectors will be supplied on 25mm - 76mm (1" - 3") silencers and flanges to BS10 (Table D) on all larger sizes. Flanges to other standards can be supplied on special quotation.

Side Entry Silencers

If these are required, please specify SN 116(SE) when ordering.

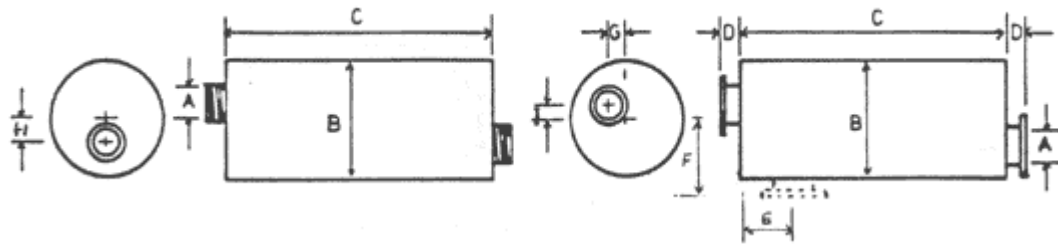

Nominal Bore (A)	Diameter (B)	Length (C)	(D)	(E)	(F)	(G)	(H)	(I)	Approx. weight (kilos)
25 (1")	95 (3¾")	381 (15")		38		14	16	8	2
32 (1¼")	95 (3¾")	457 (18")		38		17	21	11	3
38 (1½")	121 (4¾")	559 (22")		50		21	24	13	4
50 (2")	133 (5¼")	762 (30")		50		27	30	14	7
64 (2½")	178 (7")	889 (35")		50		33	38	19	13
76 (3")	203 (8")	1000 (39")		63		41	48	22	16
89 (3½")	254 (10")	1000 (39")	76	75	203	44	51	25	27
100 (4")	279 (11")	1219 (48")	76	75	216	52	59	29	38
125 (5")	356 (14")	1219 (48")	76	83	254	65	75	37	58
150 (6")	406 (16")	1524 (60")	76	95	279	78	89	44	76

Note (i) Dimensions in millimetres. (Figures in brackets are inch equivalents)

SERVAIS SILENCER TYPE SN116

Typical Noise Attenuation Graph

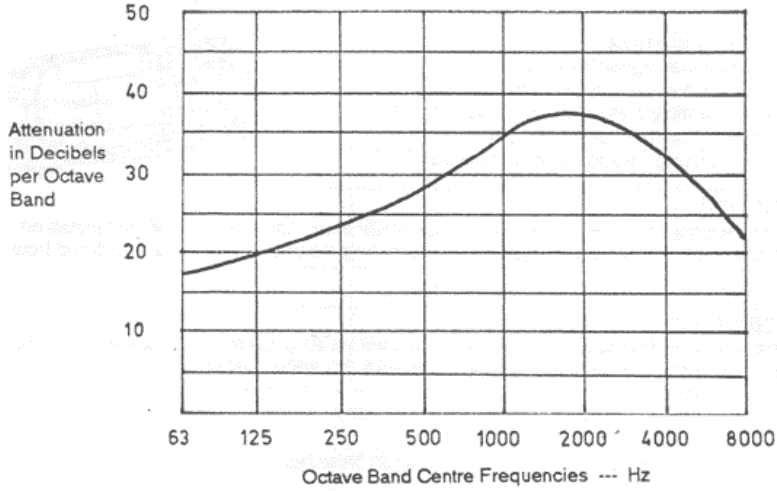

The above graph is based on simplified theoretical considerations and extrapolated from various noise tests. The actual noise reduction obtained on any particular installation will depend upon the power and type of the noise source, the local environment and the selection of the correct size of silencer for that engine.

Velocity / Resistance Graph

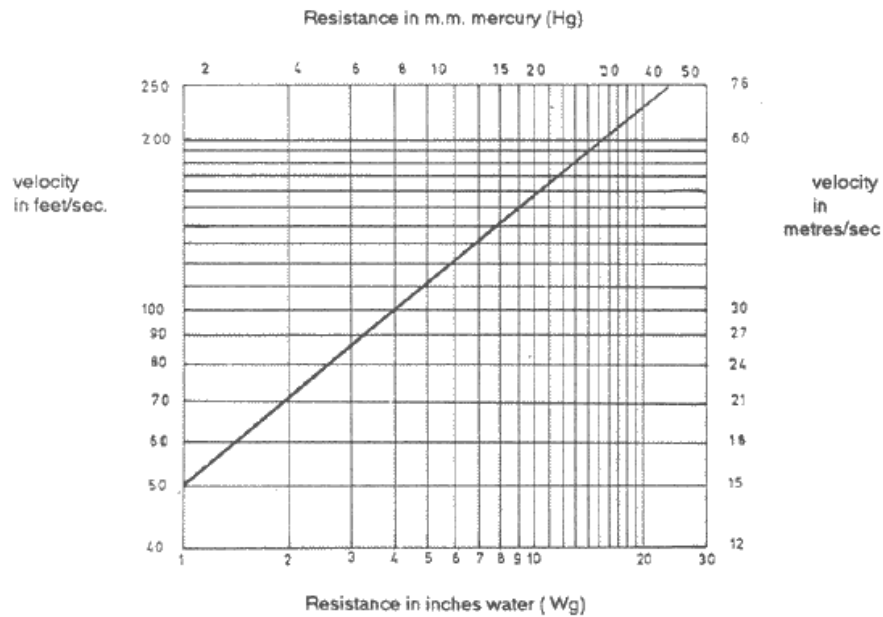

This graph is based on simplified theoretical considerations and is issued as a guide. The actual resistance experienced will depend on a number of factors affecting the individual installation. If you have any questions relating to this or any of our products, please do not hesitate to contact us.

SERVAIS SILENCER TYPE SN120

"MULTIPATH" OR "REACTIVE" INDUSTRIAL DUTY SILENCERS

General Specification

These silencers are designed on the reactive principle with twin chambers in which the exhaust gases are mixed and smoothed, thus absorbing a high proportion of the acoustic energy without causing excessive back pressure.

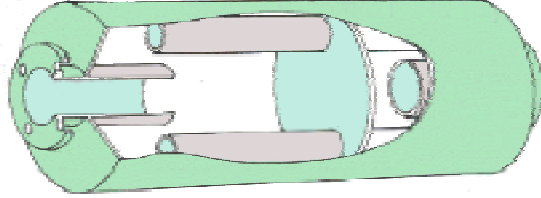

Construction

A cylindrical shell manufactured from heavy gauge sheet steel, fully welded. The end plates on 50 - 76mm nominal bore (2"-3") are from heavy steel pressings and for larger sizes these are manufactured from flat plate.

End Connectors

Unless otherwise specified, screwed BSP connectors will be supplied on 50mm - 76mm (2" -3") silencers and flanges to BS10 (Table D) on all larger sizes. Flanges to other standards can be supplied on special quotation.

Side Entry Silencers

If these are required, please specify SN 120(SE) when ordering.

SERVAIS SILENCER TYPE SN120

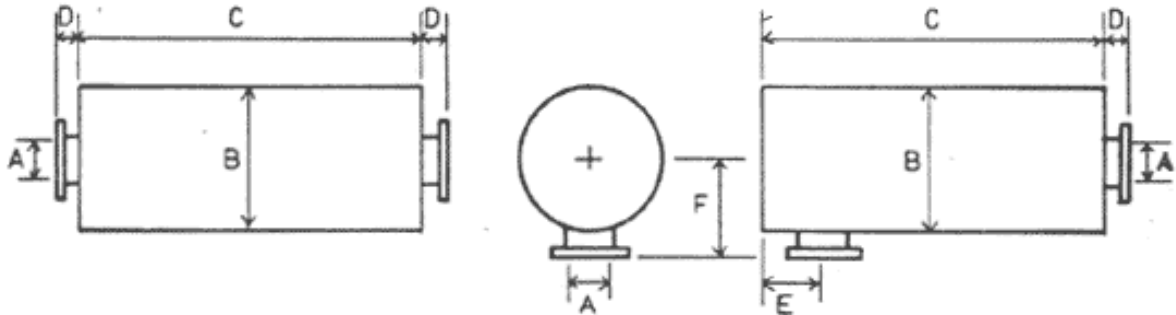

Nominal Bore (A)	Diameter (B)	Length (C)	(D)	(E)	(F)	Approx. weight (kilos)
50 (2")	250 (10")	610 (24")		60		9
64 (2½")	305 (12")	635 (25")		65		10
76 (3")	305 (12")	660 (27")		70		15
89 (3½")	356 (14")	660 (27")	76	95	254	25
100 (4")	356 (14")	711 (28")	76	95	254	26
125 (5")	406 (16")	838 (33")	76	108	279	36
150 (6")	457 (18")	991 (39")	76	121	305	50
200 (8")	559 (22")	1270 (50")	76	146	357	85
250 (10")	660 (26")	1321 (52")	89	178	419	115
300 (12")	762 (30")	1575 (62")	89	203	470	200
350 (14")	914 (36")	1829 (72")	89	229	546	400
400 (16")	1000 (39")	2032 (80")	89	254	597	500
450 (18")	1168 (46")	2337 (92")	102	292	686	750
500 (20")	1270 (50")	2540 (100")	102	318	737	900
550 (22")	1372 (54")	2743 (108")	152	325	838	1050
600 (24")	1473 (58")	2950 (116")	152	350	888	1300

- Note (i) Dimensions in millimetres. (Figures in brackets are inch equivalents)  
(ii) BSP Drain plug fitted at inlet end  
(iii) Dimension 'E' is a minimum distance

SERVAIS SILENCER TYPE SN120

Typical Noise Attenuation Graph

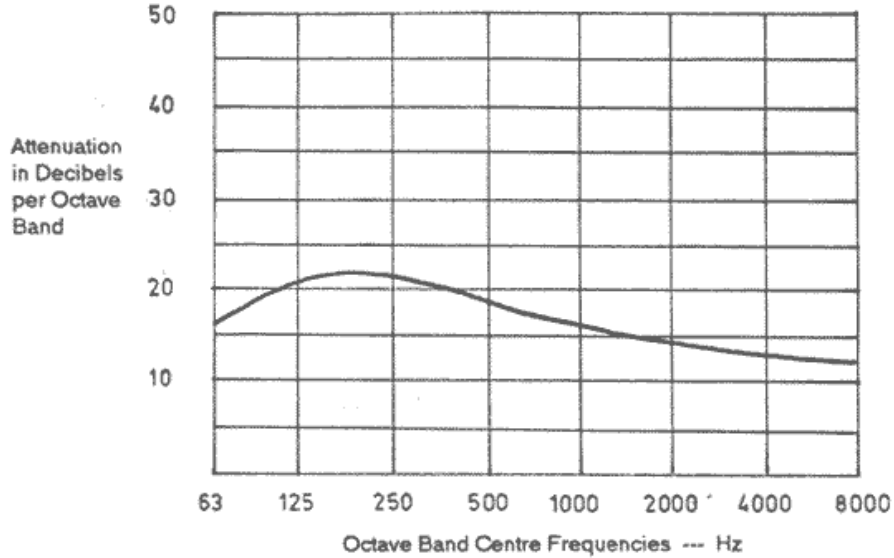

The above graph is based on simplified theoretical considerations and extrapolated from various noise tests. The actual noise reduction obtained on any particular installation will depend upon the power and type of the noise source, the local environment and the selection of the correct size of silencer for that engine.

Velocity / Resistance Graph

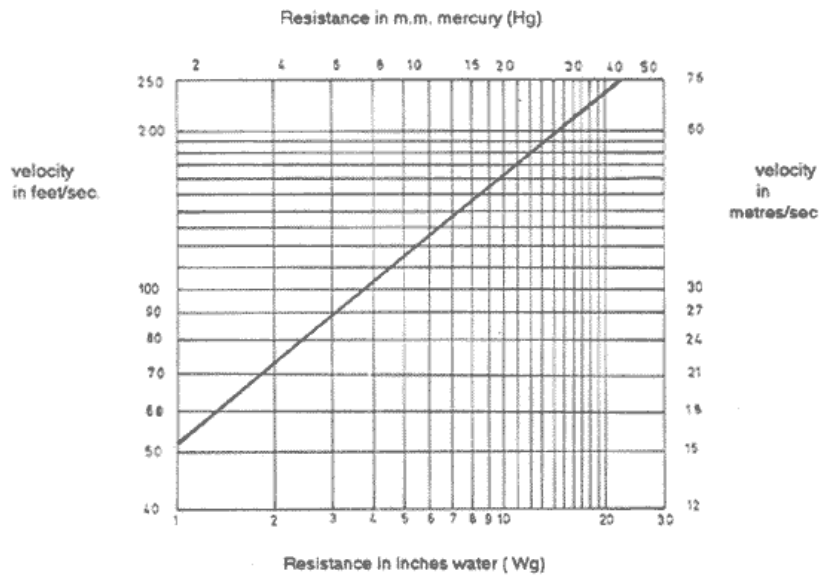

This graph is based on simplified theoretical considerations and is issued as a guide. The actual resistance experienced will depend on a number of factors affecting the individual installation. If you have any questions relating to this or any of our products, please do not hesitate to contact us.

SERVAIS SILENCERS, 409 HARLESTONE ROAD, NORTHAMPTON NN5 6PB

Telephone: +44 (0) 1604 754888 Fax: +44 (0) 1604 759548

Email: keith@servais.co.uk Web: www.servais.co.uk

## SERVAIS SILENCER TYPE SN121

### "MULTIPATH" OR "REACTIVE" MEDIUM DUTY SILENCERS

#### General Specification

These silencers are designed on the reactive principle with twin chambers in which the exhaust gases are mixed and smoothed, thus absorbing a high proportion of the acoustic energy without causing excessive back pressure.

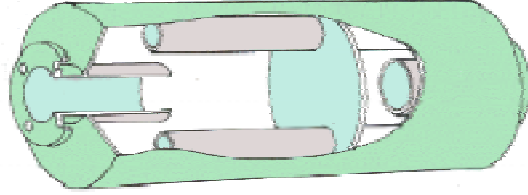

#### Construction

A cylindrical shell manufactured from heavy gauge sheet steel, fully welded. The end plates on 50 - 76mm nominal bore (2"-3") are from heavy steel pressings and for larger sizes these are manufactured from flat plate.

#### End Connectors

Unless otherwise specified, screwed BSP connectors will be supplied on 50mm - 76mm (2" -3") silencers and flanges to BS10 (Table D) on all larger sizes. Flanges to other standards can be supplied on special quotation.

#### Side Entry Silencers

If these are required, please specify SN 121(SE) when ordering.

SERVAIS SILENCER TYPE SN121

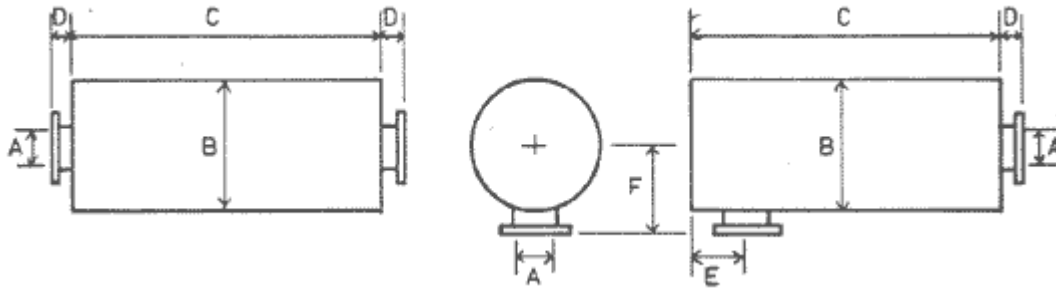

Nominal Bore (A)	Diameter (B)	Length (C)	(D)	(E)	(F)	Approx. weight (kilos)
50 (2")	250 (10")	711 (28")		63		10
64 (2½")	305 (12")	813 (32")		76		12
76 (3")	305 (12")	914 (36")		102		18
89 (3½")	356 (14")	914 (36")	76	127	254	28
100 (4")	356 (14")	1067 (42")	76	127	254	32
125 (5")	406 (16")	1245 (49")	76	152	279	48
150 (6")	457 (18")	1448 (57")	76	165	305	64
200 (8")	559 (22")	1778 (70")	76	190	356	95
250 (10")	660 (26")	2134 (84")	89	229	419	150
300 (12")	762 (30")	2591 (102")	89	254	470	270
350 (14")	914 (36")	2794 (110")	89	292	546	450
400 (16")	1000 (39")	3124 (123")	89	318	597	560
450 (18")	1168 (46")	3480 (137")	102	343	686	800
500 (20")	1270 (50")	3810 (150")	102	381	737	1000
550 (22")	1372 (54")	4140 (163")	152	325	838	1220
600 (24")	1473 (58")	4420 (174")	152	350	888	1560

- Note
- (i) Dimensions in millimetres. (Figures in brackets are inch equivalents)
  - (ii) BSP Drain plug fitted at inlet end
  - (iii) Dimension 'E' is a minimum distance

SERVAIS SILENCER TYPE SN121

Typical Noise Attenuation Graph

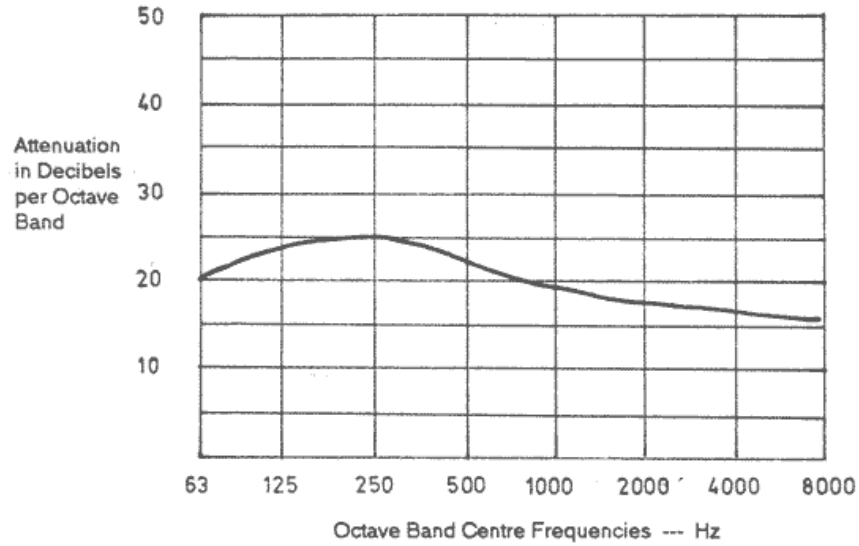

The above graph is based on simplified theoretical considerations and extrapolated from various noise tests. The actual noise reduction obtained on any particular installation will depend upon the power and type of the noise source, the local environment and the selection of the correct size of silencer for that engine.

Velocity / Resistance Graph

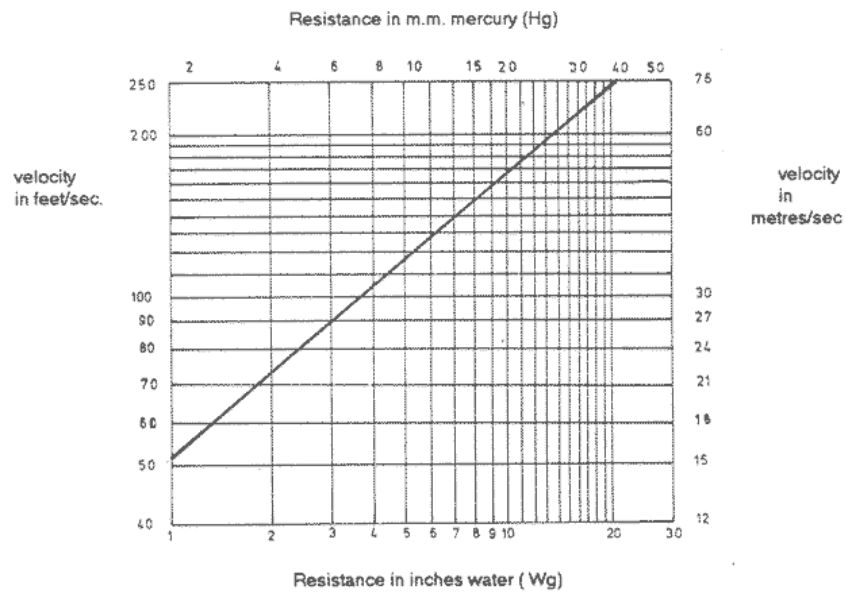

This graph is based on simplified theoretical considerations and is issued as a guide. The actual resistance experienced will depend on a number of factors affecting the individual installation. If you have any questions relating to this or any of our products, please do not hesitate to contact us.

SERVAIS SILENCER TYPE SN122

"MULTIPATH" OR "REACTIVE" RESIDENTIAL DUTY SILENCERS

General Specification

These silencers are designed on the reactive principle with twin chambers in which the exhaust gases are mixed and smoothed, thus absorbing a high proportion of the acoustic energy without causing excessive back pressure. They can also be used as a primary silencer in a multi silencer system.

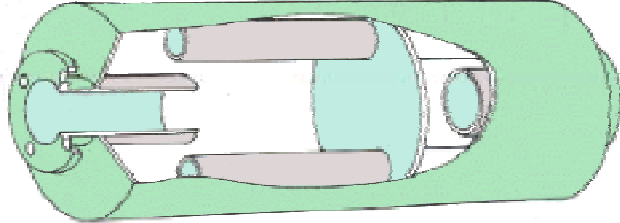

Construction

A cylindrical shell manufactured from heavy gauge sheet steel, fully welded. The end plates on 50 - 76mm nominal bore (2"-3") are from heavy steel pressings and for larger sizes these are manufactured from flat plate.

End Connectors

Unless otherwise specified, screwed BSP connectors will be supplied on 50mm - 76mm (2" -3") silencers and flanges to BS10 (Table D) on all larger sizes. Flanges to other standards can be supplied on special quotation.

Side Entry Silencers

If these are required, please specify SN 122(SE) when ordering.

SERVAIS SILENCER TYPE SN122

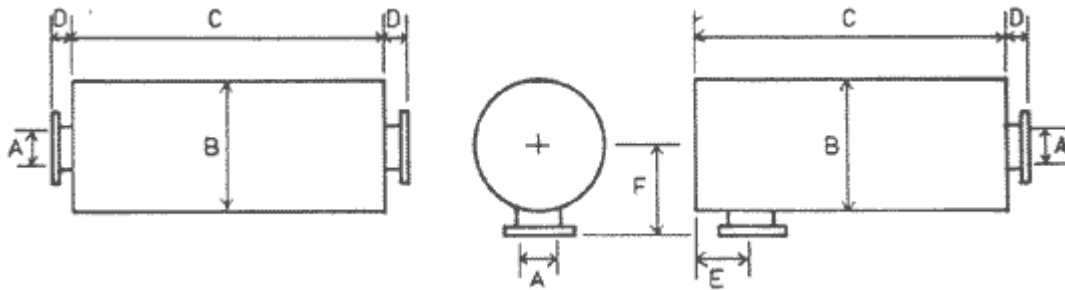

Nominal Bore (A)	Diameter (B)	Length (C)	(D)	(E)	(F)	Approx. weight (kilos)
38 (1½")	200 (8")	685 (27")		53		14
50 (2")	254 (10")	813 (32")		63		16
64 (2½")	305 (12")	914 (46")		76		22
76 (3")	355 (14")	1000 (39")		102		30
89 (3½")	406 (16")	1000 (39")	76	127	279	43
100 (4")	406 (16")	1219 (48")	76	127	279	47
125 (5")	457 (18")	1473 (58")	76	152	305	65
150 (6")	559 (22")	1676 (66")	76	165	356	90
200 (8")	660 (26")	1981 (78")	76	190	406	140
250 (10")	762 (30")	2438 (96")	89	229	470	260
300 (12")	914 (36")	2819 (111")	89	254	546	450
350 (14")	1000 (40")	3048 (120")	89	292	597	550
400 (16")	1168 (46")	3581 (141")	89	318	673	800
450 (18")	1270 (50")	3962 (156")	102	343	737	1000
500 (20")	1372 (54")	4343 (171")	102	381	787	1200
550 (22")	1524 (60")	4724 (186")	152	325	914	1580
600 (24")	1676 (66")	5000 (197")	152	350	990	2000

- Note (i) Dimensions in millimetres. (Figures in brackets are inch equivalents)  
 (ii) BSP Drain plug fitted at inlet end  
 (iii) Dimension 'E' is a minimum distance

SERVAIS SILENCER TYPE SN122

Typical Noise Attenuation Graph

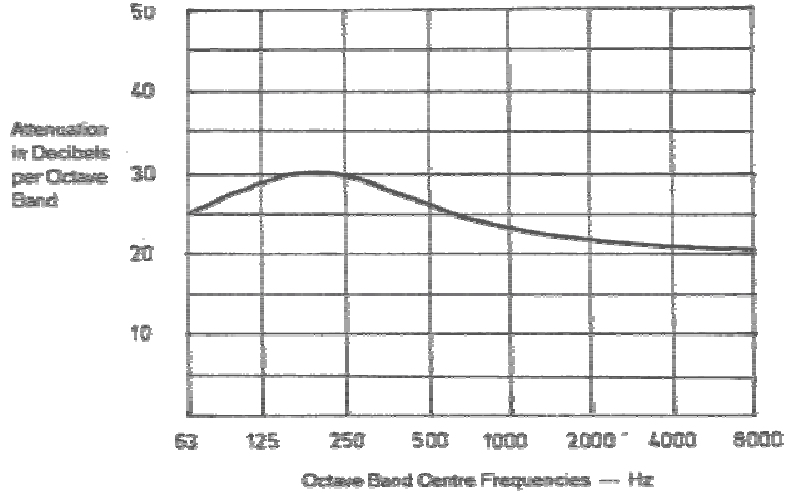

The above graph is based on simplified theoretical considerations and extrapolated from various noise tests. The actual noise reduction obtained on any particular installation will depend upon the power and type of the noise source, the local environment and the selection of the correct size of silencer for that engine.

Velocity / Resistance Graph

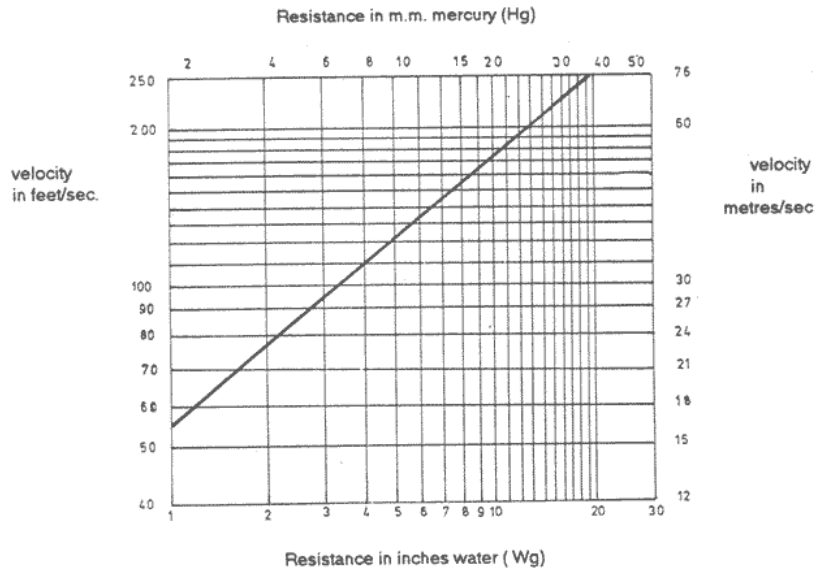

This graph is based on simplified theoretical considerations and is issued as a guide. The actual resistance experienced will depend on a number of factors affecting the individual installation. If you have any questions relating to this or any of our products, please do not hesitate to contact us.

SERVAIS SILENCER TYPE SA125"MULTIPATH" OR "REACTIVE" SPARK ARRESTING SILENCERSGeneral Specification

These silencers are designed on the reactive principle with twin chambers in which the exhaust gases are mixed and smoothed, thus absorbing a high proportion of the acoustic energy without causing excessive back pressure. The spark arresting section is designed on the vortex principle, and solid particles are separated from the gas deposited in the dust box. this can be cleaned out periodically depending on the amount of solid matter in the exhaust gases.

Construction

A cylindrical shell manufactured from heavy gauge sheet steel, fully welded. The end plates on 50 - 76mm nominal bore (2"-3") are from heavy steel pressings and for larger sizes these are manufactured from flat plate.

End Connectors

Unless otherwise specified, screwed BSP connectors will be supplied on 50mm - 76mm (2" -3") silencers and flanges to BS10 (Table D) on all larger sizes. Flanges to other standards can be supplied on special quotation.

Side Entry Silencers

If these are required, please specify SA 125(SE) when ordering.

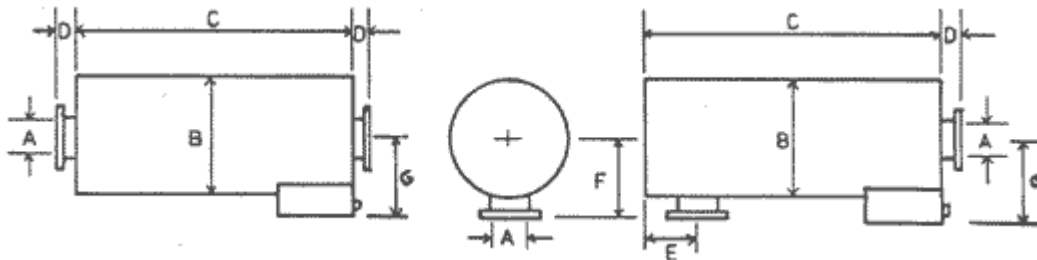

Nominal Bore (A)	Diameter (B)	Length (C)	(D)	(E)	(F)	(G)	Approx. weight (kilos)
50 (2")	254 (10")	813 (32")	38	63	165	165	18
64 (2½")	305 (12")	914 (36")	28	76	190	190	24
76 (3")	355 (14")	1000 (39")	50	102	229	229	32
89 (3½")	406 (16")	1000 (39")	76	127	279	279	43
100 (4")	406 (16")	1219 (48")	76	127	279	279	49
125 (5")	457 (18")	1473 (58")	76	152	305	305	68
150 (6")	559 (22")	1676 (66")	76	165	356	381	98
200 (8")	660 (26")	1981 (78")	76	190	406	457	150
250 (10")	762 (30")	2438 (96")	89	229	470	508	275
300 (12")	914 (36")	2819 (111")	89	254	546	610	465
350 (14")	1000 (39")	3048 (120")	89	292	597	660	570
400 (16")	1168 (46")	3581 (141")	89	318	673	737	825
450 (18")	1270 (50")	3942 (156")	102	343	737	838	1040
500 (20")	1372 (54")	4343 (171")	102	381	787	889	1300
550 (22")	1524 (60")	4724 (186")	152	325	914	991	
600 (24")	1676 (66")	5000 (197")	152	350	990	1088	

- Note (i) Dimensions in millimetres. (Figures in brackets are inch equivalents)  
(ii) BSP Drain plug fitted at inlet end  
(iii) Dimension 'E' is a minimum distance

SERVAIS SILENCER TYPE SA125

Typical Noise Attenuation Graph

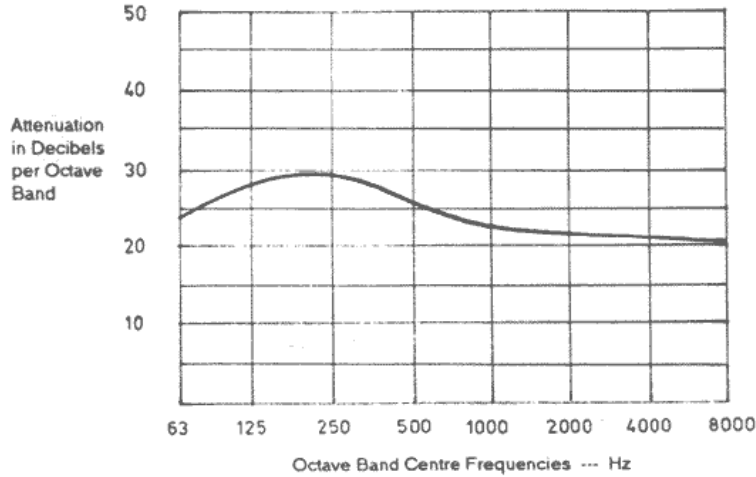

The above graph is based on simplified theoretical considerations and extrapolated from various noise tests. The actual noise reduction obtained on any particular installation will depend upon the power and type of the noise source, the local environment and the selection of the correct size of silencer for that engine.

Velocity / Resistance Graph

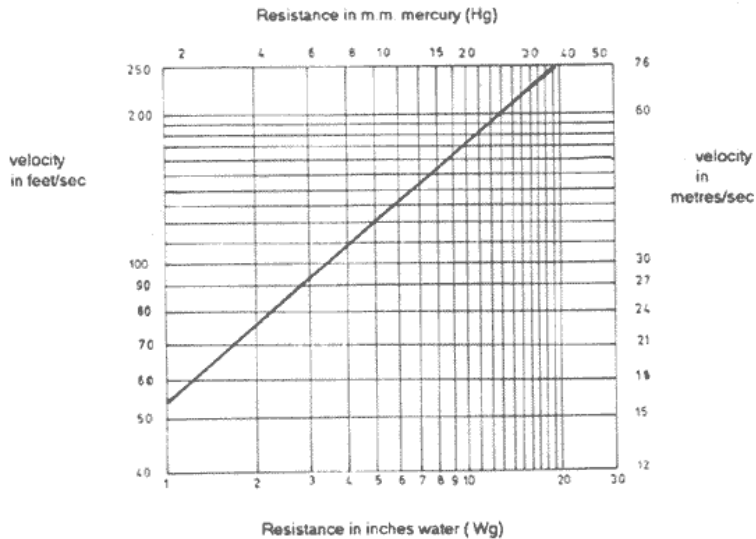

This graph is based on simplified theoretical considerations and is issued as a guide. The actual resistance experienced will depend on a number of factors affecting the individual installation. If you have any questions relating to this or any of our products, please do not hesitate to contact us.

SERVAIS SILENCER TYPE SN126

"MAXIMUM ATTENUATION" SILENCERS

General Specification

These silencers are recommended for use on diesel exhaust gas lines where noise levels have to meet the most critical specifications, without creating excessive back pressure. They are designed using the well known reactive and absorptive principles and the unique configuration combination combines these together to

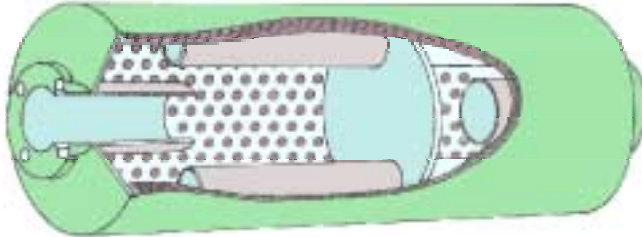

produce the most effective attenuation over a wide band. The design gives low noise breakout and surface temperatures. Use the attenuation and mass flow / resistance graphs to select the optimum size for the required gas flow.

Construction

A cylindrical shell manufactured from heavy gauge sheet steel, fully welded. All plates are manufactured from flat plate.

End Connectors

Unless otherwise specified, screwed BSP connectors will be supplied on 50mm - 76mm (2" -3") silencers and flanges to BS10 (Table D) on all larger sizes. Flanges to other standards can be supplied on special quotation.

Side Entry Silencers

If these are required, please specify SN 126(SE) when ordering.

SERVAIS SILENCER TYPE SN126

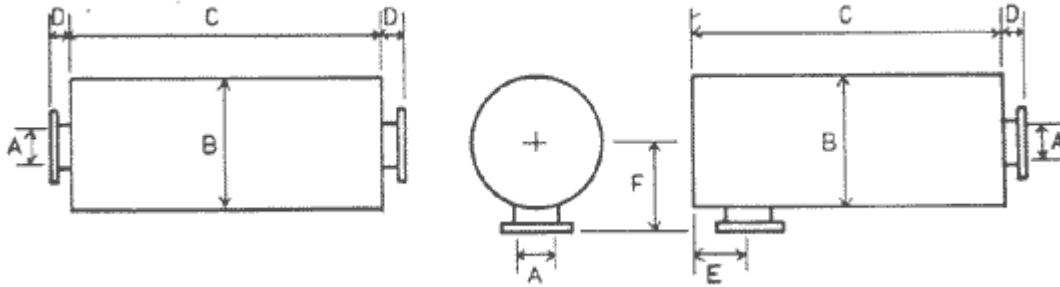

Nominal Bore (A)	Diameter (B)	Length (C)	(D)	(E)	(F)	Approx. weight (kilos)
50 (2")	305 (12")	813 (32")	38	76	203	30
64 (2½")	305 (12")	914 (36")	28	89	229	40
76 (3")	356 (14")	1000 (39")	50	102	279	48
89 (3½")	457 (18")	1219 (48")	76	102	305	70
100 (4")	559 (22")	1219 (48")	76	127	356	80
125 (5")	610 (24")	1473 (58")	76	152	381	128
150 (6")	660 (26")	1676 (66")	76	165	406	150
200 (8")	762 (30")	2000 (79")	76	190	457	250
250 (10")	914 (36")	2438 (96")	89	229	546	450
300 (12")	1067 (42")	2819 (111")	89	254	622	750
350 (14")	1067 (42")	3048 (120")	89	292	622	800
400 (16")	1219 (48")	3581 (141")	89	318	700	1150
450 (18")	1372 (54")	3962 (156")	102	343	787	
500 (20")	1524 (60")	4343 (171")	102	381	864	

Note (i) Dimensions in millimetres. (Figures in brackets are inch equivalents)  
 (ii) Dimension 'E' is a minimum distance

SERVAIS SILENCER TYPE SN126

Typical Noise Attenuation Graph

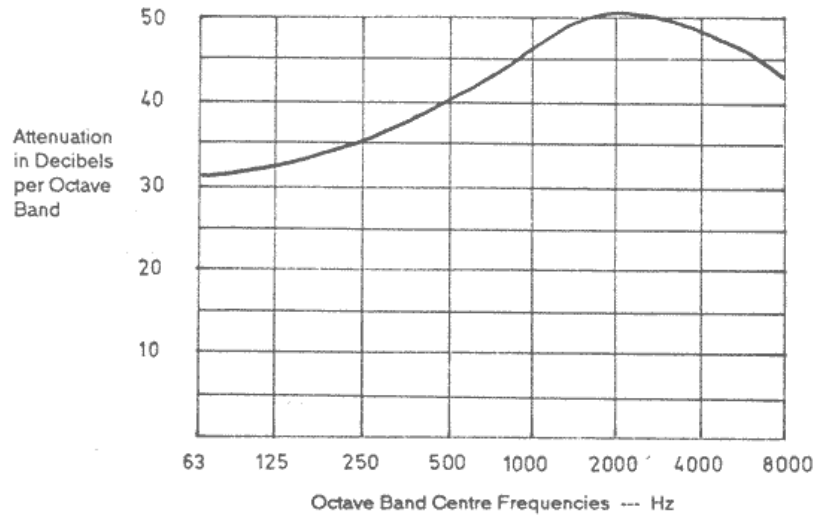

The above graph is based on simplified theoretical considerations and extrapolated from various noise tests. The actual noise reduction obtained on any particular installation will depend upon the power and type of the noise source, the local environment and the selection of the correct size of silencer for that engine.

Velocity / Resistance Graph

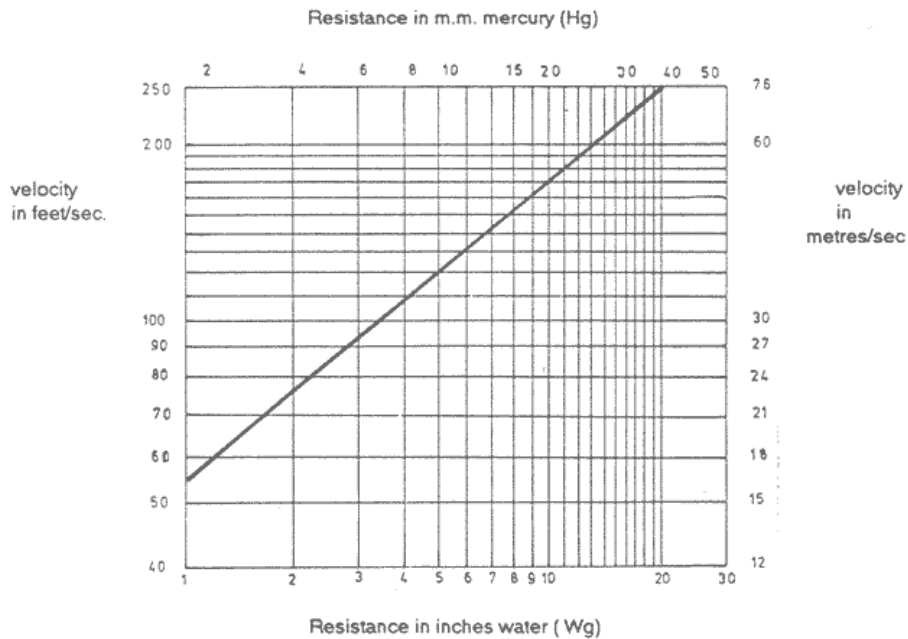

This graph is based on simplified theoretical considerations and is issued as a guide. The actual resistance experienced will depend on a number of factors affecting the individual installation. If you have any questions relating to this or any of our products, please do not hesitate to contact us.

**SERVAIS SILENCERS**

**SPARK ARRESTORS - CYCLONE TYPE SAV 123**

General Specification

These spark arrestor units consist of a device to spin the exhaust gases inside the cylindrical container and separate solid particles from the exhaust gases by centrifugal action. They conform to OCMA Publication No. MEC-1, 3.1.1.1 and certain other specifications. Customers should check the standards their equipment has to meet and order the appropriate spark arrestors.

Construction

A cylindrical shell manufactured from heavy gauge sheet steel. The diagram shows the end connection sleeved to fit over an exhaust pipe. Flanged or screwed connections can be supplied to customers specification.

Mounting

It is preferable to mount the spark arrestor in a vertical position.

Method of Cleaning

The unit may be cleaned by removing the screwed plug at the bottom of the container and cleaning out with a small flexible brush. Alternatively the whole unit may be removed and the collected dust can then be easily tipped out.

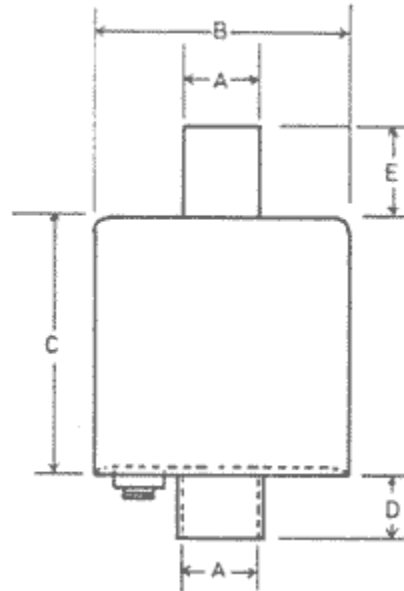

SERVAIS REFERENCE	NOMINAL BORE (A)	(B)	(C)	(D)	(E)	Approx Wt (Kg)
SAV 123 - 1½"	38 (1½")	203 (8")	203 (8")	51 (2")	152 (6")	4.2
SAV 123 - 2"	51 (2")	203 (8")	203 (8")	51 (2")	152 (6")	4.5
SAV 123 - 2½"	64 (2½")	254 (10")	254 (10")	76 (3")	203 (8")	7.3
SAV 123 - 3"	76 (3")	254 (10")	254 (10")	76 (3")	203 (8")	8.2
SAV 123 - 4"	102 (4")	305 (12")	305 (12")	102 (4")	305 (12")	12.8
SAV 123 - 5"	127 (5")	356 (14")	356 (14")	102 (4")	305 (12")	
SAV 123 - 6"	152 (6")	457 (16")	457 (16")	102 (4")	305 (12")	

Note (i) Dimensions in millimetres. (Figures in brackets are inch equivalents)

If you have any questions relating to this or any of our products, please do not hesitate to contact us.

SERVAIS SILENCERS

SERVAIS AIR FILTERS TYPE SAF

General Specification

These air filters are suitable for installing on the air intakes of diesel engines, air compressors and air blowers. Three types of filter can be supplied. The dimensions in each case are the same and the elements are interchangeable.

Type SAF-F

A polyurethane foam element. This easily cleaned porous foam element has a high dust retention capacity and gravimetric efficiency of 96-99% with BS Test Dust No. 2.

Type SAF-D

A crimped felt element reinforced with expanded aluminium mesh. The filter efficiency is 99% at 4.8 microns.

Type SAF-P

A knitted polypropylene mesh element. This is a robust unit, suitable for cleaning the air flow where a high degree of filtration is not required.

End Connectors

Screwed BSP connectors are fitted to sizes 6 - 76mm nominal bore (¼" - 3") and flanges to BS10 Table D on all larger sizes. Different types of flanges or end connectors can be supplied on special quotation.

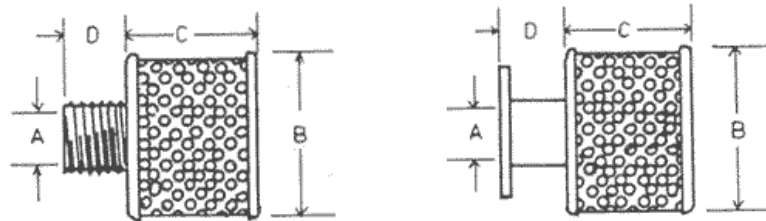

Nominal Bore (A)	Diameter (B)	Length (C)	(D)	Capacity Free Air m <sup>3</sup> /min
6 (¼")	76 (3")	35 (1 3/8")	13	0 - 0.08
10 (3/8")	76 (3")	35 (1 3/8")	13	0 - 0.08
13 (½")	76 (3")	35 (1 3/8")	19	0.08 - 0.17
19 (¾")	76 (3")	35 (1 3/8")	19	0.17 - 0.33
25 (1")	95 (3¾")	86 (3 3/8")	19	0.33 - 0.60
32 (1¼")	121 (4¾")	86 (3 3/8")	25	0.60 - 0.8
38 (1½")	121 (4¾")	86 (3 3/8")	32	0.8 - 1.4
51 (2")	140 (5½")	86 (3 3/8")	38	1.4 - 2.4
64 (2½")	140 (5½")	86 (3 3/8")	44	2.4 - 3.8
76 (3")	178 (7")	137 (5 3/8")	48	3.8 - 5.4
89 (3½")	178 (7")	137 (5 3/8")	51	5.4 - 7.1
102 (4")	203 (6")	162 (6 3/8")	51	7.1 - 10
127 (5")	254 (10")	187 (7 3/8")	51	10 - 15
152 (6")	279 (11")	227 (9")	76	15 - 22
178 (7")	356 (14")	289 (11 3/8")	76	22 - 30
203 (8")	406 (16")	346 (13 3/8")	76	30 - 40
229 (9")	457 (18")	492 (19 3/8")	76	40 - 50
254 (10")	508 (20")	492 (19 3/8")	76	50 - 60

Note (i) Dimensions in millimetres. (Figures in brackets are inch equivalents)

If you have any questions relating to this or any of our products, please do not hesitate to contact us.

## SERVAIS SILENCERS

### SERVAIS AIR FILTER SILENCERS TYPE SAFS

#### General Specification

These air filters are suitable for installing on the air intakes of air compressors and air blowers. Three types of filter can be supplied. The dimensions in each case are the same and the elements are interchangeable.

#### Type SAFS-F

A polyurethane foam element. This easily cleaned porous foam element has a high dust retention capacity and gravimetric efficiency of 96-99% with BS Test Dust No. 2.

#### Type SAFS-D

A crimped felt element reinforced with expanded aluminium mesh. The filter efficiency is 99% at 4.8 microns.

#### Type SAFS-P

A knitted polypropylene mesh element. This is a robust unit, suitable for cleaning the air flow where a high degree of filtration is not required.

The silencer section is based on the sound absorption principle. The central duct is wrapped in a protective material to prevent the acoustic filling being drawn into the air stream.

#### End Connectors

Screwed BSP connectors are fitted to sizes 6 - 76mm nominal bore ( $\frac{1}{4}$ " - 3") and flanges to BS10 Table D on all larger sizes. Different types of flanges or end connectors can be supplied on special quotation.

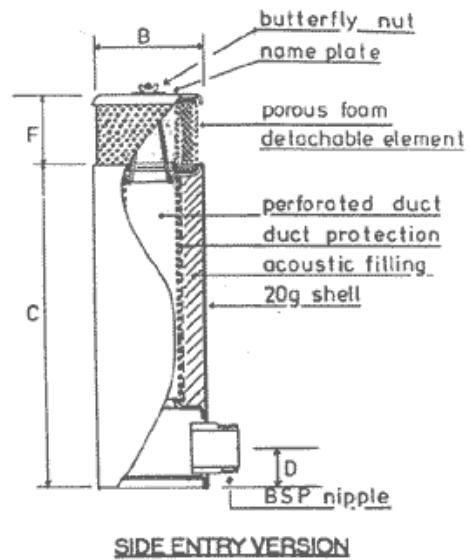

**SERVAIS AIR FILTER SILENCERS TYPE SAFS**

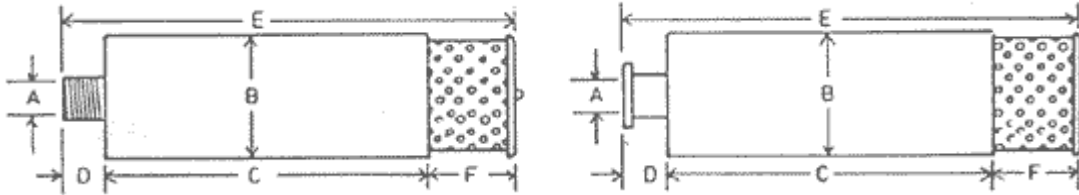

Nominal Bore (A)	Diameter (B)	Length (C)	(D)	(E)	(F)	Capacity Free Air m <sup>3</sup> /min
6 (¼")	76 (3")	102 (4")	13	149	35	0 - 0.08
10 (3/8")	76 (3")	102 (4")	13	149	35	0 - 0.08
13 (½")	76 (3")	152 (5")	19	206	35	0.08 - 0.17
19 (¾")	76 (3")	152 (5")	19	206	35	0.17 - 0.33
25 (1")	95 (3¾")	229 (9")	19	333	86	0.33 - 0.60
32 (1¼")	121 (4¾")	254 (10")	25	365	86	0.60 - 0.8
38 (1½")	121 (4¾")	305 (12")	32	422	86	0.8 - 1.4
51 (2")	140 (5½")	406 (16")	38	530	86	1.4 - 2.4
64 (2½")	140 (5½")	406 (16")	44	536	86	2.4 - 3.8
76 (3")	178 (7")	467 (18")	48	641	137	3.8 - 5.4
89 (3½")	178 (7")	467 (18")	51	644	137	5.4 - 7.1
102 (4")	203 (6")	510 (24")	51	822	162	7.1 - 10
127 (5")	254 (10")	510 (24")	51	847	187	10 - 15
152 (6")	279 (11")	752 (30")	76	1067	227	15 - 22
178 (7")	356 (14")	914 (36")	76	1280	289	22 - 30
203 (8")	406 (16")	914 (36")	76	1336	346	30 - 40
229 (9")	457 (18")	914 (36")	76	1483	492	40 - 50
254 (10")	508 (20")	1087 (42")	76	1635	492	50 - 60

Note (i) Dimensions in millimetres. (Figures in brackets are inch equivalents)

If you have any questions relating to this or any of our products, please do not hesitate to contact us.

## SERVAIS SILENCERS

### ENGINE INTAKE AIR CLEANERS TYPE SPAC

#### General Specification

These air filters are suitable for cleaning the air intakes of diesel engines and are particularly suitable for use with marinised engines.

Two sizes are offered, type SPAC and SPAC(L) for higher air flows and turbo charged engines. Each size is offered with either a porous foam element or a knitted polypropylene element, as described below.

#### Type SPAC-F and SPAC(L) - F

Air intake cleaners with porous polyurethane foam elements retained in perforated metal protection inside and out. This is an efficient cleaner with high dust retention capacity. It is easily cleaned by unscrewing the retaining screw, removing the top plate and washing the foam element in hot detergent.

#### Type SPAC-P and SPAC(L) - P

Air intake cleaners with knitted polypropylene elements retained in a perforated metal protection inside and out. This is a reliable air cleaner with low pressure drop over a wide range of air flows and is suitable where a high degree of filtration is not required. The element can be removed for cleaning by unscrewing the retaining screw, removing the top plate and lifting out the element. The element can then be washed in paraffin and drained. The element should be immersed in thin oil before reassembling.

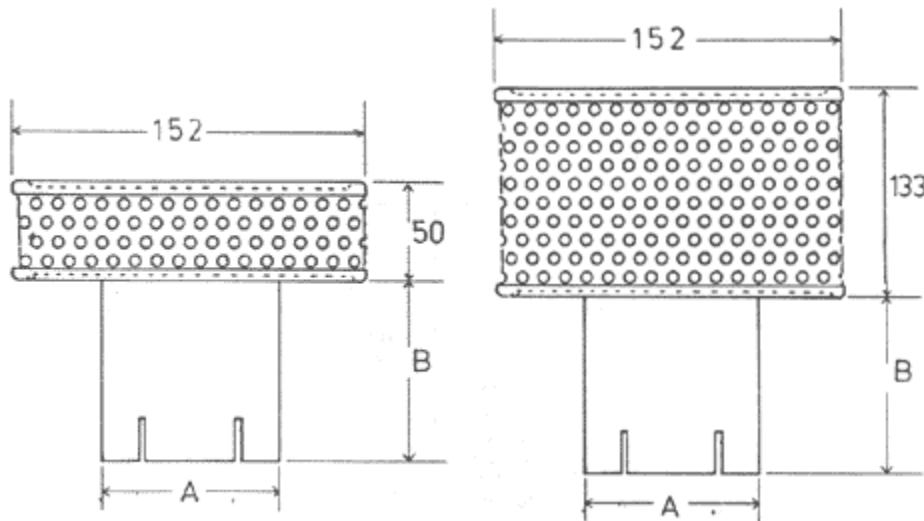

- Note (i) Dimensions A & B to customers specifications  
(ii) Dimensions in millimetres. (Figures in brackets are inch equivalents)

If you have any questions relating to this or any of our products, please do not hesitate to contact us.

**SERVAIS SILENCERS**

**GALVANISED MARINE SILENCERS TYPE SN109**

General Specification

These silencers are designed for marine use. They are constructed on the sound absorption scale, and are a sturdy reliable unit suited to the corrosive marine environment.



Construction

The silencers are constructed from heavy gauge sheet steel and plate and are fully hot dip galvanised before assembly. The end plates are detachable and this enables the silencers to be re-packed if this becomes necessary after extended use. Sizes 25 - 76mm (1" - 3") have detachable plates one end only, larger sizes have detachable plates at both ends. Very large silencers have detachable plates at intervals.

End Connectors

Either screwed BSP connectors or flanges to BS10 Table D are fitted to to sizes 25 - 76mm nominal bore (1" - 3"), and flanges to BS10 Table D on all larger sizes. Flanges to ASA, BS 4504, DIN or other standards can be supplied upon special quotation.

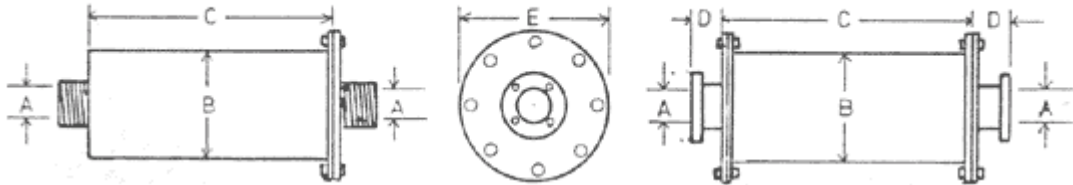

Nominal Bore (A)	Diameter (B)	Length (C)	End Projections (D)	End Plates (E)	Approx. Weight (Kilos)
25 (1")	121 (4¾")	305 (12")		165 (6½")	
32 (1¼")	121 (4¾")	457 (18")		165 (6½")	
38 (1½")	121 (4¾")	610 (24")		165 (6½")	
51 (2")	133 (5¼")	889 (35")		178 (7")	
64 (2½")	133 (5¼")	889 (35")		178 (7")	
76 (3")	178 (7")	889 (35")		229 (9")	
102 (4")	254 (10")	1019 (42")	102 (4")	305 (12")	51
127 (5")	357 (14")	1219 (48")	102 (4")	432 (17")	90
152 (6")	406 (16")	1524 (60")	102 (4")	483 (19")	115
203 (8")	508 (20")	1829 (72")	102 (4")	584 (23")	180
254 (10")	559 (22")	2438 (96")	102 (4")	635 (25")	272
305 (12")	610 (24")	2743 (108")	152 (6")	686 (27")	360
356 (14")	660 (26")	3251 (128")	152 (6")	737 (29")	460
406 (16")	762 (30")	3658 (144")	152 (6")	838 (33")	625
457 (18")	864 (34")	4064 (160")	152 (6")	940 (37")	735
508 (20")	914 (36")	4470 (176")	152 (6")	1016 (40")	907
559 (22")	1016 (40")	4877 (192")	152 (6")	1118 (44")	1275
610 (24")	1067 (42")	5740 (226")	152 (6")	1168 (46")	1475

Note (i) Dimensions in millimetres. (Figures in brackets are inch equivalents)

If you have any questions relating to this or any of our products, please do not hesitate to contact us.

SERVAIS SILENCERS

PIPEWORK

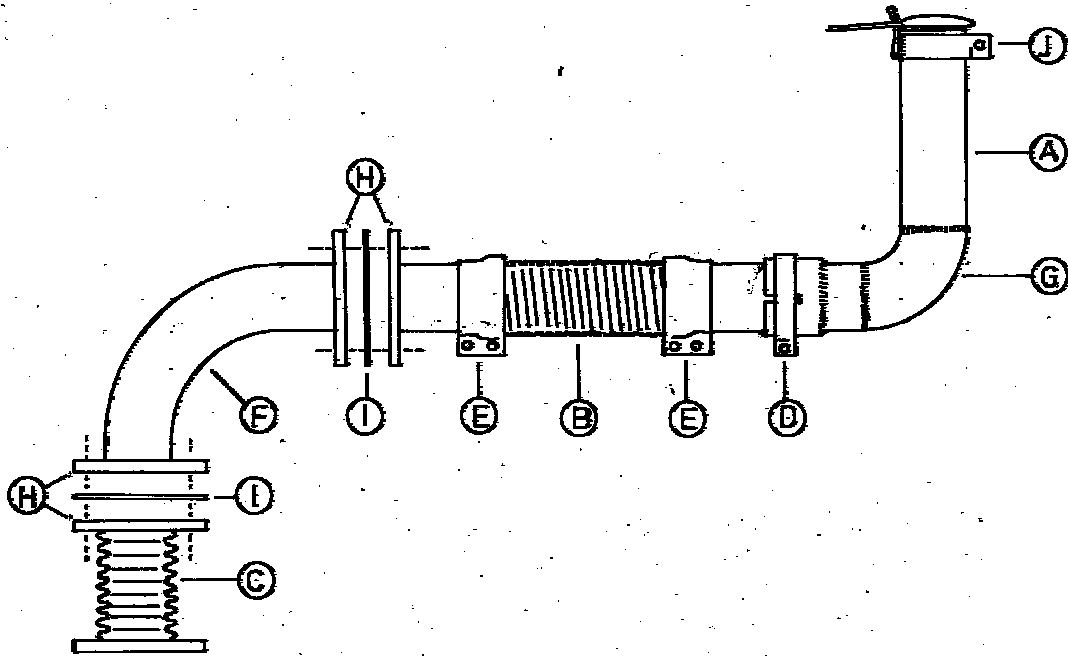

Servais supply a wide range of parts to make up pipe-work systems. These include:

(A) THIN WALLED RIGID EXHAUST TUBING Normally supplied as ERW mild steel tubing up to 200mm (8") nominal bore, and larger sizes 3mm thick spiral wound and fully welded.

(B) FLEXIBLE CONNECTIONS Electro-galvanised spiral wound flexible steel tube. This can be supplied cut to length and fitted each end with flanges or fittings to customer's specification.

(C) BELLOWS CONNECTIONS Unbraided stainless steel bellows type flexible hose. Supplied flanged at each end and distance between flange faces to customers specification.

(D) CLAMPS Servais band type clamp. A single bolt band type clamp, simple to fit and effective on sleeve pipe joints up to 100mm (4") OD.



(E) "FLEXI CLAMPS" Used to clamp spiral wound flexible tubing to rigid straight tube, without the need to weld or braze.



SERVAIS SILENCERS, 409 HARLESTONE ROAD, NORTHAMPTON NN5 6PB

Telephone: +44 (0) 1604 754888 Fax: +44 (0) 1604 759548

Email: keith@servais.co.uk Web: www.servais.co.uk

(F) BENDS Lightweight 2 x D bends. ERW mild steel tubing, bent to 90°, with centre line radius twice pipe diameter. Supplied in sizes up to 100mm (4") OD.

(G) BENDS Lightweight 1 x D bends. Lightweight mild steel spinnings cut and welded to form tight radius 90° exhaust bends.

(H) FLANGES Flat plate mild steel flanges drilled to BS10 (table D) and also to BS 4504 are held in stock in sizes from 50mm (2") to 250mm (10") nominal bore.

(I) GASKETS 3mm thick full face gaskets to suit to above flanges are held in stock.

(J) RAINCAPS The Servais style raincap is shown in the picture. The unique design ensures the rain cap is free to operate in adverse conditions. It will not jam, as so frequently happens with designs based on a hinge mechanism. It is mounted on a clip which can be slipped on to the pipe and secured in place by tightening on bolt.



A 'noiseless' version is also available for protected use where quietness is essential.

(K) Expansion sections, Y-pieces, and hanging brackets can also be manufactured to customers drawings.

If you have any questions relating to this or any of our products, please do not hesitate to contact us.

## CONDITIONS OF SALE

### GENERAL

1. In these conditions the expression 'the company' means Beepath Ltd., trading as Servais Silencers (a registered business name) and the expression 'the Contractor' means the person, firm or company whose order for goods and /or services is accepted by the company. The acceptance of this quotation or contract implies the acceptance of the conditions hereinafter set out. Unless expressly accepted in writing by the company any qualification of such conditions by the contractor shall be deemed to be inapplicable.

### PRICES

2. Unless in any particular case otherwise agreed in writing the contract price for any goods or services supplied by the company is to be subject to increase in any following cases:

- (a) In the case of any increase in the cost of labour and/or materials to the extent that any such increase shall effect the cost of producing or supplying such goods or services.
- (b) In the event of any special testing or certification required by the contractor or Government Agency or any Aviation or Factory Authority by the amount of the cost of such special testing or certification.
- (c) By the addition of the cost of or occasioned by any variation in specification of design required by the contractor or of any cost caused by or attributable to the correction of errors in drawings or specifications or schedules provided by the contractor.
- (d) In the event of any cost occasioned or attributable to any variation in the rates of production or quantities required by the contractor by the amount of any such cost.
- (e) In any of the events specified in clause 4 of these conditions by the amount of the extra costs therein mentioned.
- (f) All prices quoted are exclusive of VAT, or other taxes payable, and these will be charged additionally at the appropriate rate.

### CARRIAGE

3. Unless otherwise specified in writing prices are quoted ex-works. Carriage is charged additionally at cost.

### DELIVERY DATES

4. (a) Any time given or accepted by the company for delivery, although given or accepted in good faith, is given or accepted on the basis of being an estimate only, and if from any cause delivery is delayed the company will not be liable for any loss or damage thereby caused to the contractor.

(b) Where delivery is to be made by instalments, each delivery shall be deemed for such purpose to be the subject of a separate contract, and any failure whatsoever by the company in respect of any one delivery shall not entitle the contractor to repudiate the order or any instalments remaining to be delivered there under.

(c) If the performance of any order or any obligation there under is prevented by force majeure, the company shall be excused performance, provided that the company shall use its' best endeavours to remove such cause of non-performance, and shall continue performance there under without delay whenever such cause is removed.

(d) For the purpose of these conditions, the term 'force majeure' include acts of God, strike, lockout, labour dispute, fire, accident, lightning, earthquake, storm, flood, explosive, war restriction and any other circumstances whether similar or dissimilar, beyond the reasonable control of the company.

### PASSING OF TITLE AND RISK

5. From the time of delivery the goods shall be at the risk of the contractor who shall be solely responsible for their custody and maintenance as if it were the owner but, unless otherwise expressly agreed in writing the goods shall remain the property of the company until payment due under the contract between parties has been made in full and unconditionally or until resale of goods by the contractor bona fide in the ordinary course of its business and at full market price and the contractor shall sell as principle only. Whilst the ownership of the company continues the contractor shall keep the goods separate and identifiable from all other goods in its possession.

In the event of any resale by the contractor of the goods the beneficial entitlement of the company shall attach to the proceeds of the sale or other disposition thereof so that such proceeds or any claim therefore shall be assigned to the company and until and subject to such assignment shall be held on trust for the company by the contractor who will stand in a strictly fiduciary capacity in respect thereof.

In the event of failure to pay the price in accordance with the contractual obligations the company shall have power to re-sell the goods after reasonable notice, such power being additional to (and not in substitution for) any other power of sale arising by operation of the law or implication or otherwise.

Not later than the time of delivery of the goods to the contractor, the contractor shall insure the goods and keep the same insured while they remain the property of the company against the loss or damage by accident, fire, theft and other risks usually covered by insurance in the type of business for which the goods are for the time being used.

### DESCRIPTION

6. Every endeavour has been made to ensure that goods are accurately described and they are believed to be fit for the purposes mentioned in the company's catalogues (or on this web site), but no warranty to this effect is given and no responsibility will be accepted in the event of an error or misdescription in any catalogue (or on this web site) or damage resulting there from.

### CONSEQUENTIAL LOSS ETC.

7. In no circumstances shall the company be liable for consequential loss, damage or injury whatsoever whether direct or indirect and howsoever arising. Liability of the company shall be limited to replacement of any tools or materials supplied by the contractor or at the option of the company to the replacement of the goods or to the replacement of the invoice price thereof.

### ADVICE

8. The company assumes no obligation or liability for any advice furnished by it with respect to its goods or to the effect of those goods or for the consequences of any act done or liability incurred upon the basis of any such advice. All such advice is given and shall be deemed to have been accepted at the risk in all respects of the contractor.

### CLAIMS

9. Goods should be examined on arrival and any apparent damage or loss endorsed on the carriers receipt. A detailed claim in writing for any damage or loss must be received by the carrier and the company within 5 working days of arrival of the goods. In case of non-delivery notification should be passed to both the carrier and the company within 14 days of the date of our advice note or invoice. All claims and notifications must be sent by Recorded Delivery. Failure to comply with these conditions may invalidate any claim.

### RETURN OF GOODS

10. Any goods which have been supplied in accordance with contractors order, but which are subsequently returned will only be credited provided that:

- (a) The company's written agreement has been obtained.
  - (b) The amount credited shall be 10% less than the value at which the goods were invoiced.
- The company cannot accept cancellation of orders made specially to contractors requirements.

### TERMS OF PAYMENT

11. NETT not later than the end of the month following the date of invoice, subject to open account or satisfactory references.

### DEFAULT IN PAYMENT

12. If the contractor makes default in any payment, or commits any breach of the terms and conditions of the order, or suffers distress or execution, or becomes insolvent, or commits any act of bankruptcy, or enters into arrangements or composition with his creditors or goes into liquidation (other than solely for amalgamation or reconstruction) or if a receiver is appointed over part of the contracts business, the company may without prejudice to any rights which may have been accrued or which may accrue to it, as its option:

- (a) Require payment in advance for all or any further deliveries; or (b) Suspend any further deliveries until such default or breach is rectified; or (c) cancel the order; and /or (d) cancel or procure cancellation of any other orders which the contractor has placed with the company or any associated company, so far as any goods remain to be delivered there under.

### DISPUTES

13. (a) Representations, conditions or warranties made or purported to be give or agreed otherwise than in writing signed by a Director on behalf of the company shall be of no effect and shall not be binding and shall not form part of the contract or any inducement to the making of it.

(b) Every contract to which these conditions apply shall be deemed to be governed by English law and the High Court of Justice in London shall be the tribunal for determining all questions and disputes.

(c) In the event of any conflict or inconsistency between these conditions and any conditions sought to be imposed or to be made applicable by the contractor, these conditions shall prevail unless otherwise agreed in writing by the company.